

The background of the page is a blurred image of a red biohazard warning sign. The sign features a large black biohazard symbol in the center. Below the symbol, the word "WARNING" is printed in large, bold, black letters. Underneath "WARNING", the word "PELIGRO" is printed in smaller black letters. At the bottom of the sign, there is a line of text that reads "This collector is for..." followed by some smaller, less legible text. The ESCO logo is positioned in the top left corner of the page.

ESCO®

A Guide To Biosafety & Biosafety Cabinets

Foreword

This booklet was developed as a guide to biosafety cabinets that provides basic knowledge of biosafety and biosafety cabinets. The information presented is unbiased and generic in nature compiled with help from experienced microbiologists, engineers and safety enclosure users.

I. Biohazards and Biosafety Levels

The word biohazard is a contraction of the words biological and hazard, and defined as: "an infectious agent, or part thereof, presenting a real or potential risk to the well-being of man, animals and / or plants, directly through infection or indirectly through disruption of the environment."

Biosafety Levels 1 through 4 were established by the Centers for Disease Control (CDC) and the National Institutes of Health (NIH) and are combinations of laboratory practices and techniques, safety equipment and facilities. All of these levels are appropriate for the biohazard posed by the agents used and for the laboratory activity.

Biosafety Level 1

Practices, safety equipment and facilities appropriate for work with defined and characterized strains of viable micro organisms not known to cause disease in healthy adult humans. The laboratory is not necessarily separated from the general traffic patterns in the building. Work is generally conducted on open bench tops using standard microbiological practices. Special containment equipment or facility design is neither required nor generally used. Laboratory personnel have specific training in the procedures conducted in the laboratory and are supervised by a scientist with general training in microbiology or a related science. A biohazard safety cabinet is generally not required for work involving these agents.

Biosafety Level 2

Practices, safety equipment and facilities appropriate for work done with a broad spectrum of indigenous moderate-risk agents present in the community and associated with human disease in varying severity. It differs from biosafety level 1 in that:

- a) laboratory personnel have specific training in handling pathogenic agents and are directed by competent scientists;
- b) access to the laboratory is limited when work is being conducted;
- c) extreme precautions are taken with contaminated sharp items; and
- d) certain procedures in which infectious aerosols or splashes may be created are conducted in biological safety cabinets or other physical containment equipment. A Class I or Class II biohazard safety cabinet is highly recommended for work involving these agents.

Biosafety Level 3

Practices, safety equipment and facilities appropriate for work done with indigenous or exotic agents with a potential for respiratory transmission

which may cause serious and potentially lethal infection. More emphasis is placed on primary and secondary barriers to protect personnel in the contagious area, the community, and the environment from exposure to potentially infectious aerosols. A Class I or Class II biohazard safety cabinet is required for work involving these agents.

Biosafety Level 4

Practices, safety equipment and facilities appropriate for work done with dangerous and exotic agents which pose a high risk of life threatening disease. May be transmitted via the aerosol route, and for which there is no available vaccine or therapy. Members of the laboratory staff have specific and thorough training in handling extremely hazardous infectious agents and they understand the primary and secondary containment functions of the standard and special practices, the containment equipment, and the laboratory design characteristics. They are supervised by competent scientists who are trained and experienced in working with these agents. Access to the laboratory is strictly controlled by the laboratory director. The facility is either in a separate building or in a controlled area within a building, which is completely isolated from all other areas of the building. A specific facility operations manual is prepared or adopted. A Class III biohazard safety cabinet is required for work involving these agents.

From: *Biosafety in Microbiology and Biomedical Laboratories*, U.S. Department of Health and Human Services, HHS publication (CDC) 99-8395, 4th ed. April 1999. p 11-14.

Table 1. Summary of Biosafety Levels and Infections Agents

Biosafety Level	Infectious Agents	Examples	Practices and Techniques	Safety Equipment (Primary Barriers)	Facilities (Secondary Barriers)
1	Not known to consistently cause disease in healthy adults	Bacillus subtilis, Naegleria gruberi, Infectious canine, hepatitis virus, E.coli	Standard Microbiological practices	None Required	Open benchtop sink required.
2	Associated with human disease. Primary hazards are percutaneous injury, ingestion, mucous membrane exposure	Measles virus, salmonellae, Toxoplasma spp, Hepatitis B Virus.	<p>Level 1 plus:</p> <ul style="list-style-type: none"> Limited access Biohazard warning signs “Sharps” precautions Biosafety manual defining any needed waste decontamination or medical surveillance policies Respiratory protection as required 	<p>Primary barriers:</p> <p>Class I or II BSCs or other physical containment devices used for all manipulations of agents that cause splashes or aerosols of infectious materials.</p> <p>Personal protective equipment:</p> <p>lab coats, gloves, face protection as needed</p>	<p>Level 1 plus:</p> <ul style="list-style-type: none"> Autoclave available
3	Indigenous or exotic agents with potential for aerosol transmission, disease may have serious or lethal consequences	M. Tuberculosis, St. louis encephalitis virus, Coxiella Burnetii, Bacillus anthracis (production level)	<p>Level 2 plus:</p> <ul style="list-style-type: none"> Controlled access Decontamination of waste Decontamination of lab clothing Baseline serum samples of lab personnel 	<p>Primary barriers:</p> <p>Class I or II BSCs or other physical containment devices used for all open manipulations of agents.</p> <p>Personal protective equipment:</p> <p>lab clothing, gloves, respiratory protection as needed</p>	<p>Level 2 plus:</p> <ul style="list-style-type: none"> Physical separation from access corridors Self-closing, double door access Exhaust air not recirculated Negative airflow into laboratory
4	Dangerous / exotic agents that pose a high risk of life threatening disease. Aerosol-transmitted lab infections or related agents with unknown risk of transmission	Ebola zaire, Sin Nombre Virus, Rift Valley Fever	<p>Level 3 plus:</p> <ul style="list-style-type: none"> Clothing change before entry into lab Shower on exit All material decontaminated on exit from lab 	<p>Primary barriers:</p> <p>All procedures conducted in Class III or I or II BSCs in combination with full-body, air-supplied, positive-pressure personnel suit</p>	<p>Level 3 plus:</p> <ul style="list-style-type: none"> Separate building or isolated zone Dedicated supply/exhaust vacuum, and decontamination systems Additional requirements as outlined in Biosafety in Microbiological and Biomedical Laboratories

Source: Biosafety in Microbiology and Biomedical Laboratories, U.S. Department of Health and Human Services, HHS publication (CDC) 99-8395, 4th ed. p 52-53.

II. Biological Safety Cabinets

The terms biological safety cabinet and biosafety cabinet have been widely used to describe a variety of containment devices equipped with HEPA filter(s), designed to provide personnel or both personnel and product protection from biohazardous materials. The terms should only be applied to those devices that meet the requirements of Class I, II, or III specifications, based on their construction, airflow velocities and patterns, and their exhaust systems.

Major International Standards for Biosafety Cabinets :

- ◆ American Standard NSF 49:2002
- ◆ European Standard EN 12469:2000
- ◆ Australian Standard AS 2252
- ◆ Japanese Standard JIS K 3800:2000

Table 2. Biohazard Safety Cabinet Classes

Class	Inflow V (m/s)	Recycle Air (%)	Exhaust Air (%)	Control Plenum Surrounded by	Exhaust Alternatives	Biosafety Level
I	US:0.38 EN:0.70	0	100	Outside Air	Inside room / Hard duct	1, 2 & 3
II A1	US:0.38 EN:0.40	70	30	Outside Air	Inside room / Thimble duct	1, 2 & 3
II A2	US:0.50 EN:0.40	70	30	Negative Plenum	Inside room / Thimble duct	1, 2 & 3
II B1	US:0.50 EN:0.40	30	70	Negative Plenum	Hard duct only	1, 2 & 3
II B2	US:0.50 EN:NA	0	100	Negative Plenum	Hard duct only	1, 2 & 3
III	Closed: >50"WC	0	100	Negative Plenum	Inside room / Hard duct	1, 2, 3 & 4

Source: *Laboratory Biosafety Manual. Second Edition (revised). Interim guidelines. World Health Organization. p32.*

Class I Biohazard Safety Cabinet

The Class I cabinet has the most basic and rudimentary design of all biohazard safety cabinetry available today. A stream of inward air moving into the cabinet contains aerosols generated during microbiological manipulations. It then passes through a filtration system that traps all airborne particles and contaminants. Finally, clean, decontaminated air is exhausted from the cabinet. The filtration system usually consists of a pre-filter and a HEPA (High Efficiency Particulate Air) filter.

Although the Class I cabinet protects the operator and the environment from exposure to biohazards, it does not prevent samples being handled in the cabinet from coming into contact with airborne contaminants that may be present in room air. Naturally, there is a possibility of cross-contamination that may affect experimental consistency. Consequently the scope and application of Class I cabinets is limited and it is largely considered obsolete.

All Class I biohazard safety cabinets are suitable for work with microbiological agents assigned to biological safety levels 1, 2 and 3.

Class II Biohazard Safety Cabinet

Like Class I safety cabinets, Class II cabinets have a stream of inward air moving into the cabinet. This is known as the inflow and it prevents the aerosol generated during microbiological manipulations to escape through the front opening. However, unlike Class I cabinets, the inflow on Class II cabinets flows through the front inlet grille, near the operator. None of the unfiltered inflow air enters the work zone of the cabinet, so the product inside the work zone is not contaminated by the outside air.

A feature unique to Class II cabinets is a vertical laminar (unidirectional) HEPA-filtered air stream that descends downward from the interior of the cabinet. This continuously flushes the cabinet interior of airborne contaminants and protects samples being handled within the cabinet from contamination and is known as the downflow.

The differences between the various Class II cabinets available lie primarily with the percentage of air exhausted to that of air re-circulated from the common air plenum. In addition, different Class II cabinets have different means of cabinet exhaust. Some cabinets may exhaust air directly back to the laboratory, while others may exhaust air through a dedicated ductwork system to the external environment.

Despite these differences, all Class II cabinets, like Class I cabinets, protect both the operator and environment from exposure to biohazards. In addition, Class II cabinets also protect product samples from contamination during microbiological manipulations within the cabinet interior and are all suitable for work with agents assigned to biological safety levels 1, 2 and 3.

Class II Type A (A1/A2) Biohazard Safety Cabinet

The Class II Type A biohazard safety cabinet is the most common Class II cabinet. It is also the most common safety cabinet of all the different types available. It has a common plenum from which 30% of air is exhausted, and 70% re-circulated to the work area as the downflow.

Type A cabinets exhaust air directly back to the laboratory, and they may contain positive pressure contaminated plenums. When toxic chemicals must be employed as an adjunct to microbiological processes, these cabinets should not be used. Exhaust HEPA filtration only removes airborne aerosols including biohazards, and not chemical fumes.

The Class II Type A1 has the positively-pressurized contaminated plenum bordering the ambient environment, and therefore is less safe than the Class II Type A2 that has a negative pressure surrounding the positively pressurized contaminated plenum. In case there is a leakage on the positive plenum, the leaking aerosol will be pulled by the negative pressure back to the positive plenum, and it won't leak outside. Because of the safety issue, the Type A1 design is now considered obsolete. In the A2 cabinet, about 70% of air from the positive plenum is re-circulated as downflow, and the remaining 30% is discharged to the lab through the exhaust filter.



Fig 2. Class II Type A2 BSC

Class II Type B Biohazard Safety Cabinets

The main difference between Type A and Type B cabinet is: Type B cabinets must be operated with an external blower and it exhausts air to the external environment via a dedicated ductwork system. Without the external blower, the cabinets internal blower will blow the air (and microbiological agents) inside the work zone through the front operator, towards the operators face, creating a dangerous situation. This cabinet is not self-balancing in the sense that its own blower can only create downflow and the cabinet relies on the external blower to create inflow.

On all Type B cabinets, environmental protection may be enhanced by installing a scrubbing system between the exhaust of the biohazard and the final exhaust point outside the building to neutralize the chemical fumes present in exhaust air.

Although Type B cabinets are commonly used when chemicals are involved in your work processes, they theoretically provide an increased level of safety as compared to other Type A cabinets. By exhausting air directly to the external environment, they provide an additional “fail-safe” in the event that the regular exhaust HEPA filtration ceases to function.

Class II Type B1 Biohazard Safety Cabinet

The Class II Type B1 biohazard safety cabinet was originally specified by the American National Cancer Institute. It has a common plenum from which 70% of air is exhausted, and 30% re-circulated to the work area as the downflow.

Type B1 cabinets also have a dedicated exhaust feature that eliminates re-circulation when work is performed towards the back within the interior of the cabinet. Toxic chemicals employed as an adjunct to microbiological processes should only be employed if they do not interfere with work when re-circulated in the downflow.

Class II Type B2 Biohazard Safety Cabinet

In the Class II Type B2 cabinet all inflow and downflow air is exhausted after HEPA filtration to the external environment without recirculation within the cabinet. Type B2 cabinets are suitable for work with toxic chemicals employed as an adjunct to microbiological processes under all circumstances since no re-circulation occurs. In theory, Type B2 cabinets may be considered to be the safest of all Class II biohazard safety cabinets since the total exhaust feature acts as a fail-safe in the event that the downflow and / or exhaust HEPA filtration systems cease to function normally.



Fig 3. Class II Type B2

Class III Biohazard Safety Cabinet

The Class III biohazard safety cabinet provides an absolute level of safety, which cannot be attained with Class I and Class II cabinets. All Class III cabinets are usually of welded metal construction and are designed to be gastight. Work is performed through glove ports in the front of the cabinet. During routine operation, negative pressure relative to the ambient environment is maintained within the cabinet. This provides an additional fail-safe mechanism in case physical containment is compromised.

On all Class III cabinets, a supply of HEPA filtered air provides product protection and prevents cross contamination of samples. Exhaust air is usually HEPA filtered and incinerated. Alternatively, double HEPA filtration with two filters in series may be utilized. Materials are transferred into the cabinet using a pass-through unit installed at the side of the work area. Class III cabinets usually exhaust air back to the laboratory; however, air may also be exhausted via a dedicated ductwork system to the external environment. When a dedicated ductwork system is employed, they are also suitable for work employing toxic chemicals as an adjunct to microbiological processes.

All Class III biohazard safety cabinets are suitable for work with microbiological agents assigned to biological safety levels 1, 2, 3 and 4. They are frequently specified for work involving the most lethal biological hazards.



Fig 4. Class III BSC

HEPA & ULPA Filter

The HEPA filter is the heart of the biosafety cabinet. The HEPA filter is a disposable dry-type filter, constructed of boron silicate microfibers cast into a thin sheet, much like a piece of paper

- ◆ HEPA: High Efficiency Particulate Air: Modern "American-convention" HEPA: 99.99% at 0.3 microns
- ◆ ULPA: Ultra Low Penetration Air: Modern "American-convention" ULPA: 99.999% at 0.12 microns

HEPA / ULPA filter construction:

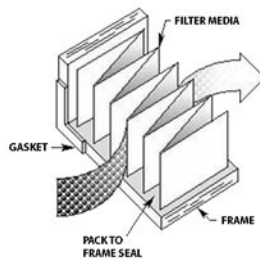

Fig 5. Pack is glued into a frame - Frame is gasketed to form final assembly

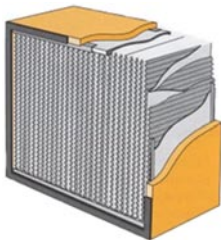

Fig 6. Separator Type

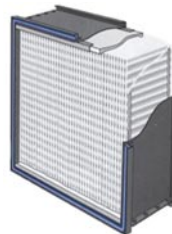

Fig 7. Separatorless Type

HEPA/ULPA filters are designed to remove a broad range of airborne contaminants, including:

- ◆ Fine dust
- ◆ Smoke
- ◆ Bacteria (typical size: 500 to 0.3 micron)
- ◆ Soot
- ◆ Pollen
- ◆ Radioactive particles
- ◆ Impurity ion -> can affect Integrated Circuit speed

III. Proper Selection, Installation & Safe Use Of BSCs

A. Selection of A Biological Safety Cabinet

A BSC should be selected primarily in accordance with the type of protection needed: product protection; personnel protection against Risk Group 1–4 microorganisms; personnel protection against exposure to radionuclides and volatile toxic chemicals; or a combination of these. Table 3 shows which BSCs are recommended for each type of protection.

Table 3. Biohazard Safety Cabinet Selection

Type of protection	BSC Selection
Personnel Protection, microorganisms in Risk Groups 1-3	Class I, Class II, Class III
Personnel Protection, microorganisms in Risk Groups 4, glove box laboratory	Class III
Personnel Protection, microorganisms in Risk Groups 4, suit laboratory	Class I, Class II
Product Protection	Class II, Class III only if laminar flow included
Volatile radionuclide / chemical protection, minute amounts	Class IIB1, Class IIA2 vented to the outside
Volatile radionuclide / chemical protection	Class I, Class IIB2, Class III

Source: Laboratory Biosafety Manual. Second Edition (revised). Interim guidelines. World Health Organization. p29.

Volatile or toxic chemicals should not be used in BSCs that recirculate exhaust air to the room, i.e. Class I that are not ducted to building exhaust systems, or Class IIA1 or Class IIA2 cabinets. Class II B1 cabinets are acceptable for work with minute amounts of volatile chemicals and radionuclides. A Class IIB2 cabinet, also called a total exhaust cabinet, is necessary when significant amounts of radionuclides and volatile chemicals are expected to be used.

B. Using Biological Safety Cabinets in The Laboratory

1. Location

The velocity of air flowing through the front opening into a BSC is about 0.45 m/s. At this velocity the integrity of the directional air inflow is fragile and can be easily disrupted by air currents generated by people walking close to the BSC, open windows, air supply registers, and opening and shutting doors.

Ideally, BSCs should be situated in a location remote from traffic and potentially disturbing air currents. Whenever possible a 30 cm clearance should be provided behind and on each side of the cabinet to allow easy access for maintenance. A clearance of 30–35 cm above the cabinet may be required to provide for accurate air velocity measurement across the exhaust filter and for exhaust filter changes.

2. Operators

If BSCs are not used properly, their protective benefits may be greatly diminished. Operators need to be careful to maintain the integrity of the front opening air inflow when moving their arms into and out of cabinets. Arms should be moved in and out slowly, perpendicular to the front opening.

Manipulations of materials within BSCs should be delayed for about 1 min after placing hands and arms inside to allow the cabinet to adjust and to “air sweep” the surface of the hands and arms. The number of movements across the front opening should also be minimized by placing all necessary items into the cabinet before beginning manipulations.

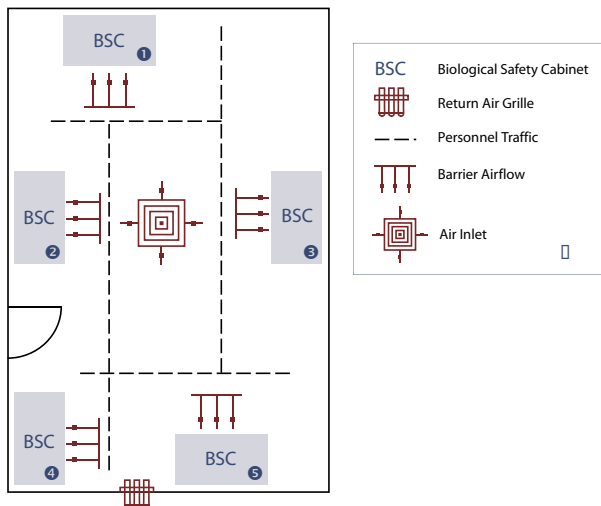

Fig 8. A typical Class II Cabinet Installation

3. Material Placement

The front intake grill of Class II BSCs must not be blocked with paper, equipment or other items. Materials to be placed inside the cabinet should be surface-decontaminated with 70% alcohol. Work may be performed on disinfectant-soaked absorbent towels to capture splatters and splashes.

All materials should be placed as far back in the cabinet, towards the rear edge of the work surface, as practical without blocking the rear grill. Aerosol-generating equipment (e.g. mixers, centrifuges, etc.) should be placed towards the rear of the cabinet. Bulky items, such as biohazard bags, discard pipette trays and suction collection flasks should be placed to one side of the interior of the cabinet. Active work should flow from clean to contaminated areas across the work surface.

The autoclavable biohazard collection bag and pipette collection tray should not be placed outside the cabinet. The frequent in-and-out movement needed to use these containers is disruptive to the integrity of the cabinet's air barrier, and can compromise both personnel and product protection.

4. Operation and Maintenance

Most BSCs are designed to permit operation 24 h/day, and investigators find that continuous operation helps to control the levels of dust and particulate materials in the laboratory. Class IIA1 and IIA2 BSCs exhausting to the room or connected by thimble connections to dedicated exhaust ducts can be turned off when not in use. Other types such as IIB1 and IIB2 BSCs, which have hard-duct installations, must have air flow through them at all times to help maintain room air balance.

Cabinets should be turned on at least 5 min before beginning work and after completion of work to allow the cabinet to "purge", i.e. to allow time for contaminated air to be removed from the cabinet environment.

All repairs made on BSCs should be made by a qualified technician. Any malfunction in the operation of the BSC should be reported and repaired before the BSC is used again.

5. Ultraviolet Lights

Ultraviolet lights are not required in BSCs. If they are used, they must be cleaned weekly to remove any dust and dirt that may block the germicidal effectiveness of the light. Ultraviolet light intensity should be checked when the cabinet is recertified to ensure that light emission is appropriate. Ultraviolet lights must be turned off while the room is occupied, to protect eyes and skin from inadvertent exposure.

6. Open Flames

Open flames should be avoided in the near microbe-free environment created inside the BSC. They disrupt the air flow patterns and can be dangerous when volatile, flammable substances are also used. To sterilize bacteriological

loops, micro-burners or electric “furnaces” are available and are preferable to open flames.

7. Spills

A copy of the laboratory’s protocol for handling spills should be posted, read and understood by everyone who uses the laboratory. When a spill of biohazardous material occurs within a BSC, cleanup should begin immediately, while the cabinet continues to operate. An effective disinfectant should be used and applied in a manner that minimizes the generation of aerosols. All materials that come into contact with the spilled agent should be disinfected and / or autoclaved.

8. Annual Certification

The functional operation and integrity of each BSC should be certified to national or international performance standards at the time of installation and regularly thereafter by qualified technicians, according to the manufacturer’s instructions.

Evaluation of the effectiveness of cabinet containment should include tests for cabinet integrity, HEPA filter leaks, downflow velocity profile, face velocity, negative pressure/ventilation rate, air flow smoke pattern, and alarms and interlocks.

Optional tests for electrical leaks, lighting intensity, ultraviolet light intensity, noise level and vibration may also be conducted. Special training, skills and equipment are required to perform these tests and it is highly recommended that they are undertaken by a qualified professional.

9. Cleaning and Disinfection

All items within BSCs, including equipment, should be surface-decontaminated and removed from the cabinet when work is completed, since residual culture media may provide an opportunity for microbial growth. The interior surfaces of BSCs should be decontaminated before and after each use. The work surfaces and interior walls should be wiped with a disinfectant that will kill any microorganisms that might be found inside the cabinet. At the end of the work day, the final surface decontamination should include a wipe-down of the work surface, the sides, back and interior of the glass. A solution of bleach or 70% alcohol should be used where effective for target organisms. A second wiping with sterile water is needed when a corrosive disinfectant, such as bleach, is used. It is recommended that the cabinet be left running. If not, it should be run for 5 min in order to purge the atmosphere inside before it is switched off.

10. Decontamination

BSCs must be decontaminated before filter changes and before being moved. The most common decontamination method is by fumigation with formaldehyde gas. BSC decontamination should be performed by a qualified professional.

11. Personal protective equipment

Personal protective clothing should be worn whenever using a BSC. Laboratory coats are acceptable for work being performed at Biosafety Levels 1 and 2. A solid front, back-closing laboratory gown provides better protection and should be used at Biosafety Levels 3 and 4 (except for suit laboratories). Gloves should be pulled over the wrists of the gown rather than worn inside. Elasticized sleeves can be worn to protect the investigator's wrists. Masks and safety glasses may be required for some procedures.

12. Alarms

BSCs can be equipped with one of two kinds of alarm. Sash alarms are found only on cabinets with sliding sashes. The alarm signifies that the operator has moved the sash to an improper position. Corrective action for this type of alarm is returning the sash to the proper position. Air-flow alarms indicate a disruption in the cabinet's normal air-flow pattern. This represents an immediate danger to the operator or product. When an air-flow alarm sounds, work should cease immediately and the laboratory supervisor should be notified. Manufacturers' instruction manuals should provide further details. Training in the use of BSCs should cover this aspect.

13. Supplementary Information

Selecting the correct type of BSC, installing it, using it properly and annually certifying its operation are complex processes. It is highly recommended that they proceed under the supervision of a well-trained and experienced biosafety professional. The professional should be highly familiar with the relevant literature listed in the References section, and should have been trained on all aspects of BSCs. Operators should receive formal training in the operation and use of BSCs.

C. Safe Use of Biosafety Cabinets

1. Using BSCs: Startup

- ◆ Wear gloves for hand protection
- ◆ Load the cabinet with all items required prior to starting work and surface decontaminate
- ◆ Surface decontaminate the work surface, side walls and inner back walls
- ◆ Allow the work zone air to purge for a few minutes before commencing work
- ◆ Do not overcrowd the work zone
- ◆ Close the drain valve before operation

2. Using BSCs: Operation

- ◆ Do not obstruct the front or back air grilles
- ◆ Work as far in to the cabinet as possible
- ◆ Minimize arm movement; make slow movements to avoid disrupting cabinet airflow
- ◆ When removing arms from cabinet be sure to surface decontaminate first, and move arms out slowly of the cabinet (in direction perpendicular to plane of work zone opening)
- ◆ Minimize external airflow disturbances
- ◆ Work from “clean to dirty”
- ◆ Biohazard collection bags should be placed inside the cabinet instead of outside
- ◆ Use absorbent pads on the work surface where appropriate to minimize splatter and aerosol generation in case of a spillage
- ◆ Surface decontaminate before removing potentially contaminated items from the interior
- ◆ Place aerosol-generating instruments as far in to the interior of the cabinet as possible
- ◆ Clean materials should be at least 150mm away from aerosol generating objects to minimize the chance for cross contamination
- ◆ Hold lids / covers above dishes / sample plates in order to prevent impingement of downward air
- ◆ Do not use a gas flame whenever possible as it interferes with airflow
- ◆ Put air turbulence generating equipment such as centrifuge, blender, or sonicator in the back 1/3 of the cabinet

3. Bunsen Burner

Burners can cause an outflow of air from inside the cabinet that can endanger the operator. On Class II cabinets, protection against cross contamination may also be compromised. There have been incidents where the sash of a recirculating Class II safety cabinet was closed while the burner was still on, causing heat build up in the cabinet that damaged the filters.

Bunsen Burner Safety:

1. An electronic burner which automatically reduces the gas supply to maintain a smaller flame during periods of non-use
2. An emergency shut off valve should be easily accessible near to the cabinet in case of an emergency.

3. The burner should be placed as far into the cabinet working space as possible to minimize its effect on cabinet performance.
4. A solenoid valve can be interlocked with the gas supply to automatically shut off the burner

4. Using BSCs: Shutdown

Note: operate the cabinet continuously whenever possible to maximize protection- Surface decontaminate all items

- ◆ Seal biohazard bags if used
- ◆ Surface decontaminate the cabinet innerside walls, back wall, work surface, drain pan and the inner side of the sliding sash / hinged window
- ◆ Allow work zone air to purge
- ◆ When available: install front closure or close sash and activate UV lamp (if desired)

5. User maintenance

- ◆ Pre-filter replacements once every 3 months
- ◆ UV lamp replacement once a year
- ◆ Operational verification if appropriate (e.g. Alarm checks, basic airflow measurements etc.)

IV. Biohazard Spills & Cleanup Procedures

A. Inside the BSC:

- ◆ Wait at least five minutes to allow the BSC to contain aerosols.
- ◆ Wear lab coat, safety glasses and gloves during cleanup.
- ◆ Allow cabinet to run during cleanup.
- ◆ Apply disinfectant and allow a minimum of 20 minutes contact time.
- ◆ Wipe up spillage with disposable disinfectant-soaked paper towel.
- ◆ Wipe the walls, work surface and any equipment in the cabinet with a disinfectant-soaked paper towel.
- ◆ Discard contaminated disposable materials using appropriate biohazardous waste disposal procedures (e.g. autoclave or BFI).
- ◆ Place contaminated reusable items in biohazard bags, autoclavable pans with lids or wrap in newspaper before autoclaving and cleanup.
- ◆ Expose non-autoclavable materials to disinfectant (20 minute contact time) before removal from the BSC.
- ◆ Remove protective clothing used during cleanup and place in a biohazard bag for autoclaving.
- ◆ Run cabinet 10 minutes after cleanup before resuming work or turning cabinet off.

B. Inside the lab, outside the BSC:

- ◆ Call the biosafety office if the material is BSL-2 or greater containment.
- ◆ Clear area of all personnel. Wait at least 15 minutes for aerosol to settle before entering spill area.
- ◆ Remove any contaminated clothing and place in biohazard bag to be autoclaved.
- ◆ Put on a disposable gown, safety glasses and gloves.

Initiate cleanup with disinfectant as follows:

1. Place dry paper towel on spill (to absorb liquids); then layer a second set of disinfectant soaked paper towels over the spill.
2. Encircle the spill with additional disinfectant being careful to minimize aerosolization while assuring adequate contact.
3. Decontaminate all items within spill the area.
4. Allow 20 minutes contact time to ensure germicidal action of disinfectant.
5. Wipe equipment with appropriate disinfectant.
6. Discard contaminated disposable materials using appropriate biohazardous waste disposal procedures (e.g., autoclave or BFI).
7. Disinfect reusable items

C. Inside The Centrifuge

- ◆ Clear area of all personnel.
- ◆ Wait 30 minutes for aerosol to settle before attempting to clean up spill.
- ◆ Wear a lab coat, safety glasses and gloves during cleanup.
- ◆ Remove rotors and buckets to nearest biological safety cabinet for cleanup.
- ◆ Thoroughly disinfect inside of centrifuge.
- ◆ Discard contaminated disposable materials using appropriate biohazardous waste disposal procedures (e.g., autoclave or BFI).

D. Outside The Lab, In Transit

- ◆ Transport labelled biohazardous material in an unbreakable, well-sealed primary container placed inside of a second unbreakable, lidded container (cooler, plastic pan or pail) labelled with the biohazard symbol.
- ◆ Should a spill occur in a public area, do not attempt to clean it up without appropriate personal protective equipment.
- ◆ Secure the area, keeping all people well clear of the spill.
- ◆ Call professional help to assist in cleanup.
- ◆ Stand by during spill response and cleanup activity and provide assistance only as requested or as necessary.

From: UCSD Biosafety handbook, UCSD EH&S Biosafety Team 1996.
THE UNIVERSITY OF CALIFORNIA, USA. p95-97.

V. References:

1. **User & Service Manual.** *Labculture® Class II Type A2 Biohazard Safety Cabinet: ESCO Micro Pte Ltd.*
2. **Biosafety in Microbiological and Biomedical Laboratories (BMBL).** *4th Edition. Office of Health and Safety (OHS), Centers for Disease Control and Prevention (CDC). US Department of Health.*
3. **Laboratory Biosafety Manual.** *Second Edition (revised). Interim guidelines. World Health Organization.*
4. **UCSD Biosafety handbook, UCSD EH&S Research Community for Biosafety.** 1996.
5. **UCSD Biosafety handbook, UCSD EH&S Biosafety Team 1996.** *THE UNIVERSITY OF CALIFORNIA.*



PRODUCTS AVAILABLE FROM ESCO BIOTECH:

**Vertical Laminar Flow Cabinets
Horizontal Laminar Flow Cabinets
PCR Vertical Laminar Flow Cabinets**

**Class II Biosafety Cabinets
Class III Biosafety Cabinets**

**Cytotoxic Cabinets
IVF Cabinets
Weighing Cabinets
Animal Handling Workstations**

Custom-Made Clean-Air / Containment Workstations

Your local distributor:

Esco Biotechnology Equipment Division

21 Changi South Street 1
Singapore 486777

tel: +65 6542 0833 fax: +65 6542 6920
email: biotech@escoglobal.com
website: biotech.escoglobal.com

